

Assembly Instructions – s-drive rod style under bin conveyor

1. Install the transitions by placing the transition in the bin gate discharge as shown. Secure with self-tapping and self-screwing bolts.

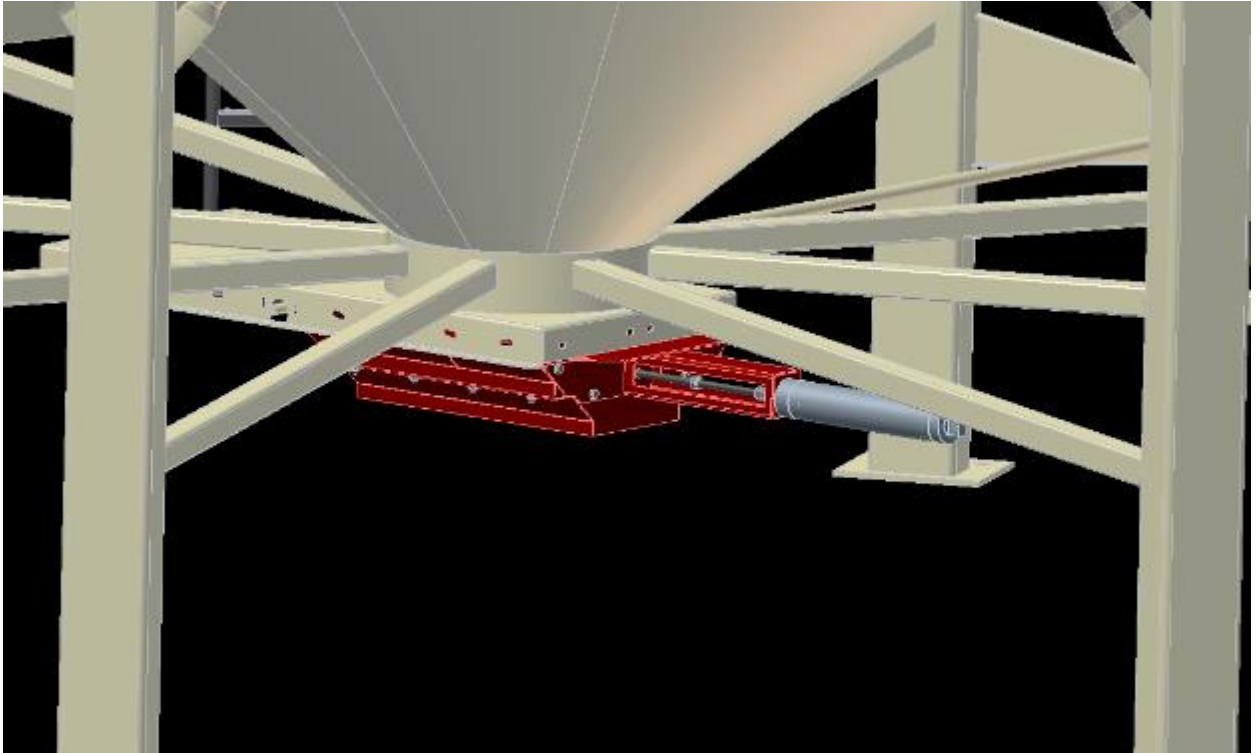

2. Place 2 middle sections under the bin and bolt them together

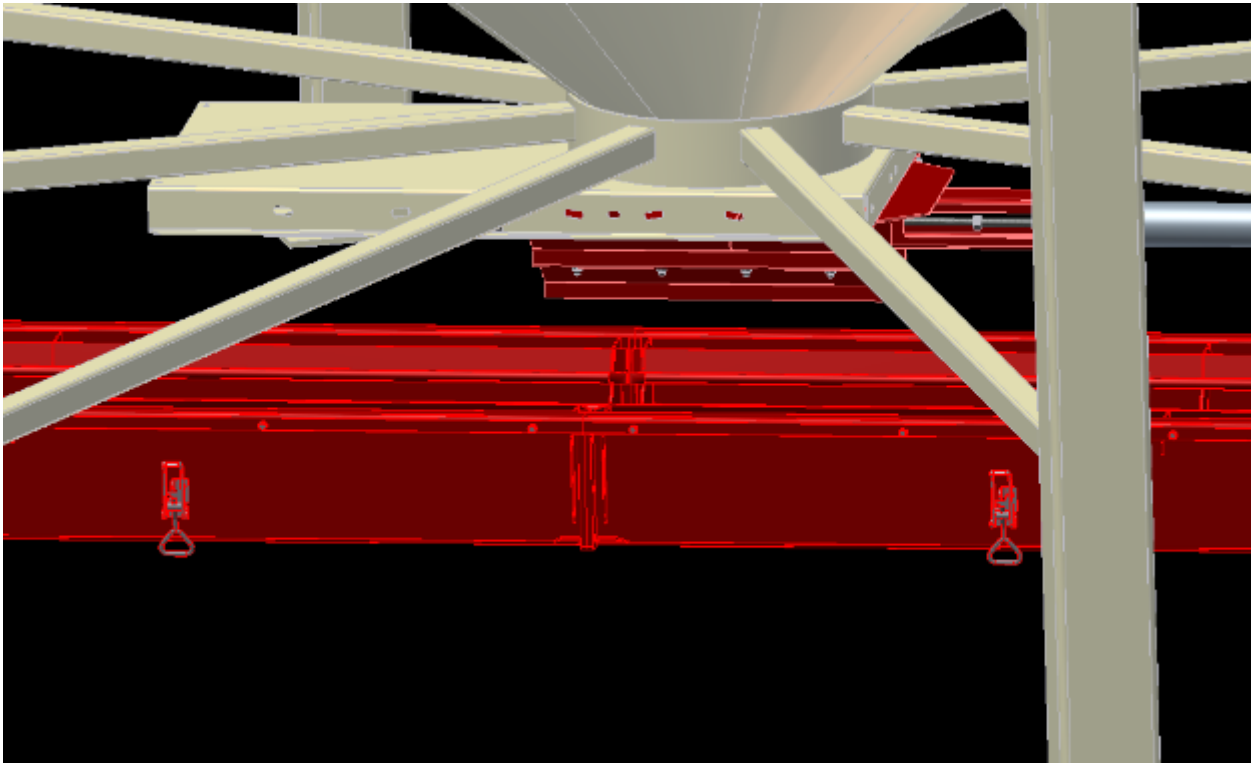

3. Put the galvanized “splash cover” in place under the air gate but do not attach it yet. The tabs on the cover should be pointing up.

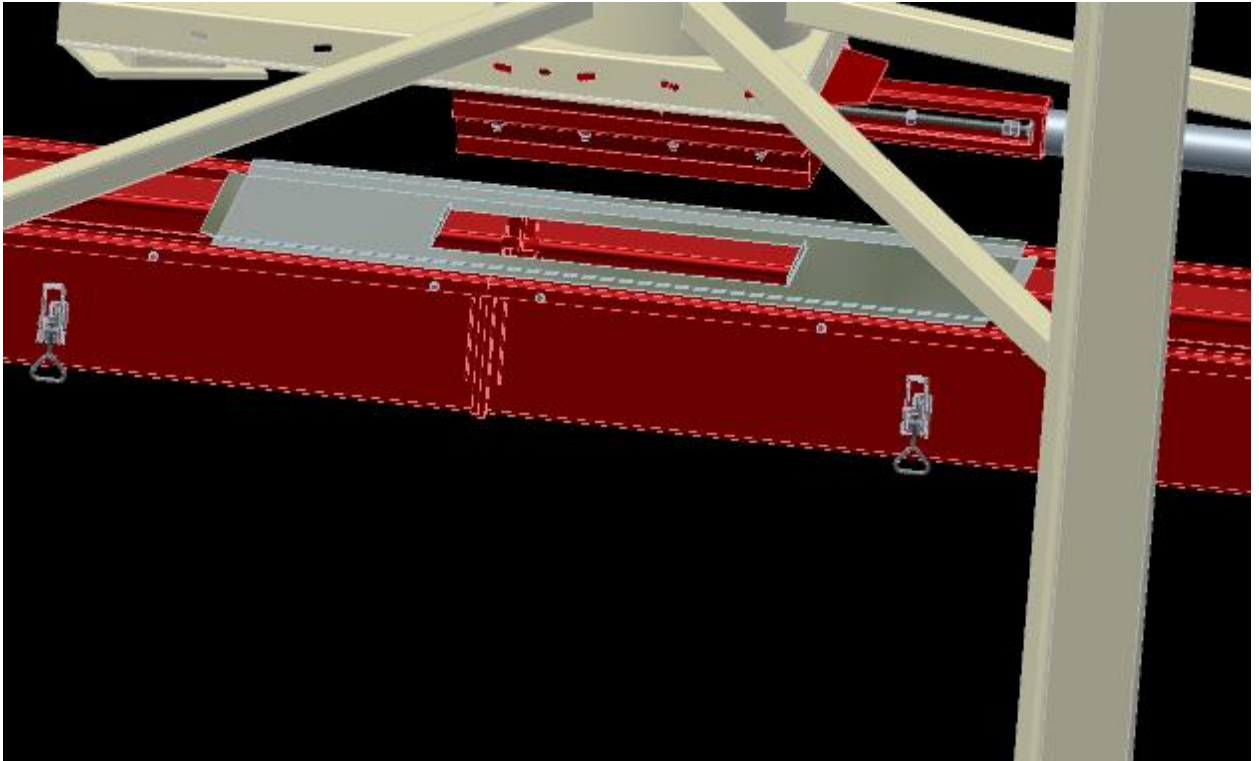

4. Raise the 2 sections of the under bin conveyor and mount on the support bracket. There are 2 brackets per bin. The brackets should be installed as close as possible to the bin legs.

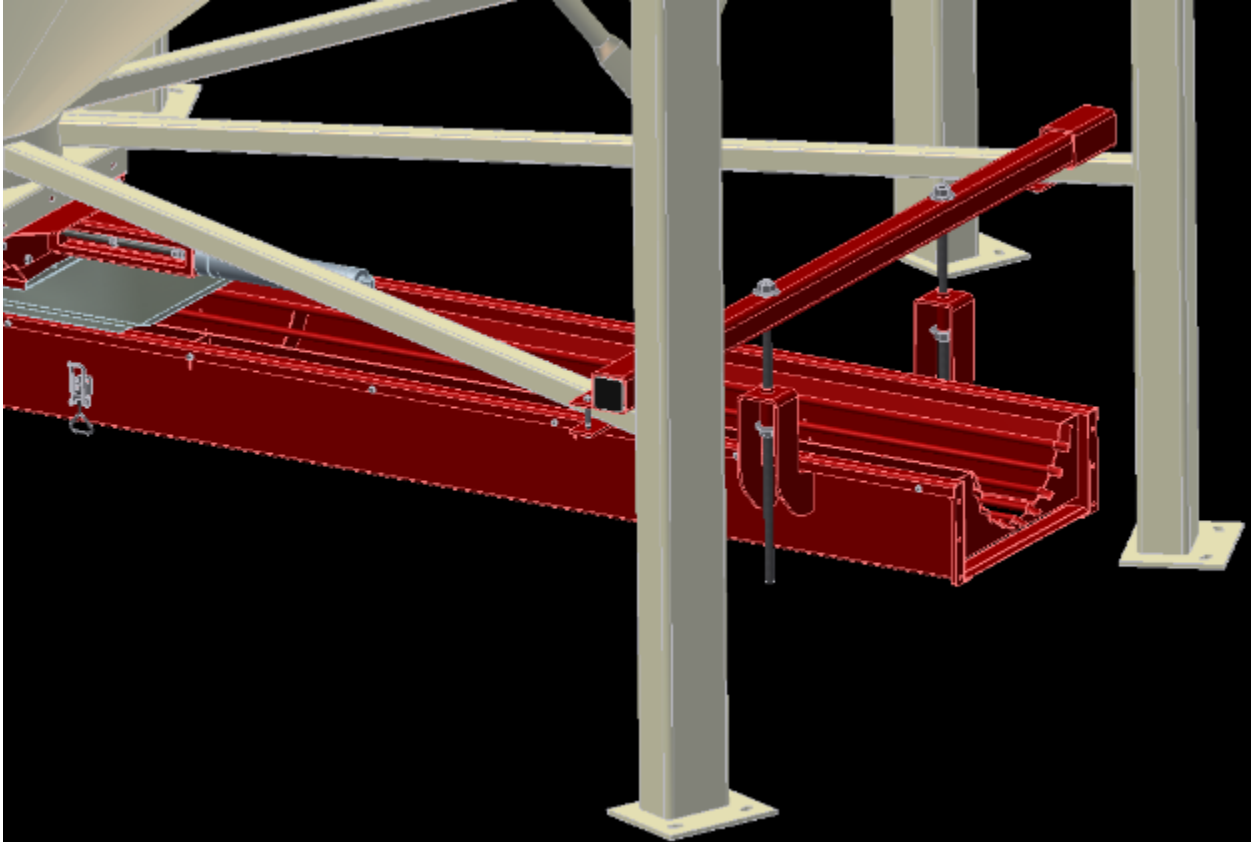

5. Follow the above for each of the bins

6. Attach the s-drive section in a similar way as the middle sections. The s-drive can be installed at any location along the under bin conveyor. Note: the s-drive is reversible, however it will have more capacity in one direction than the other. **The slack adjuster should point in the direction of maximum capacity.**

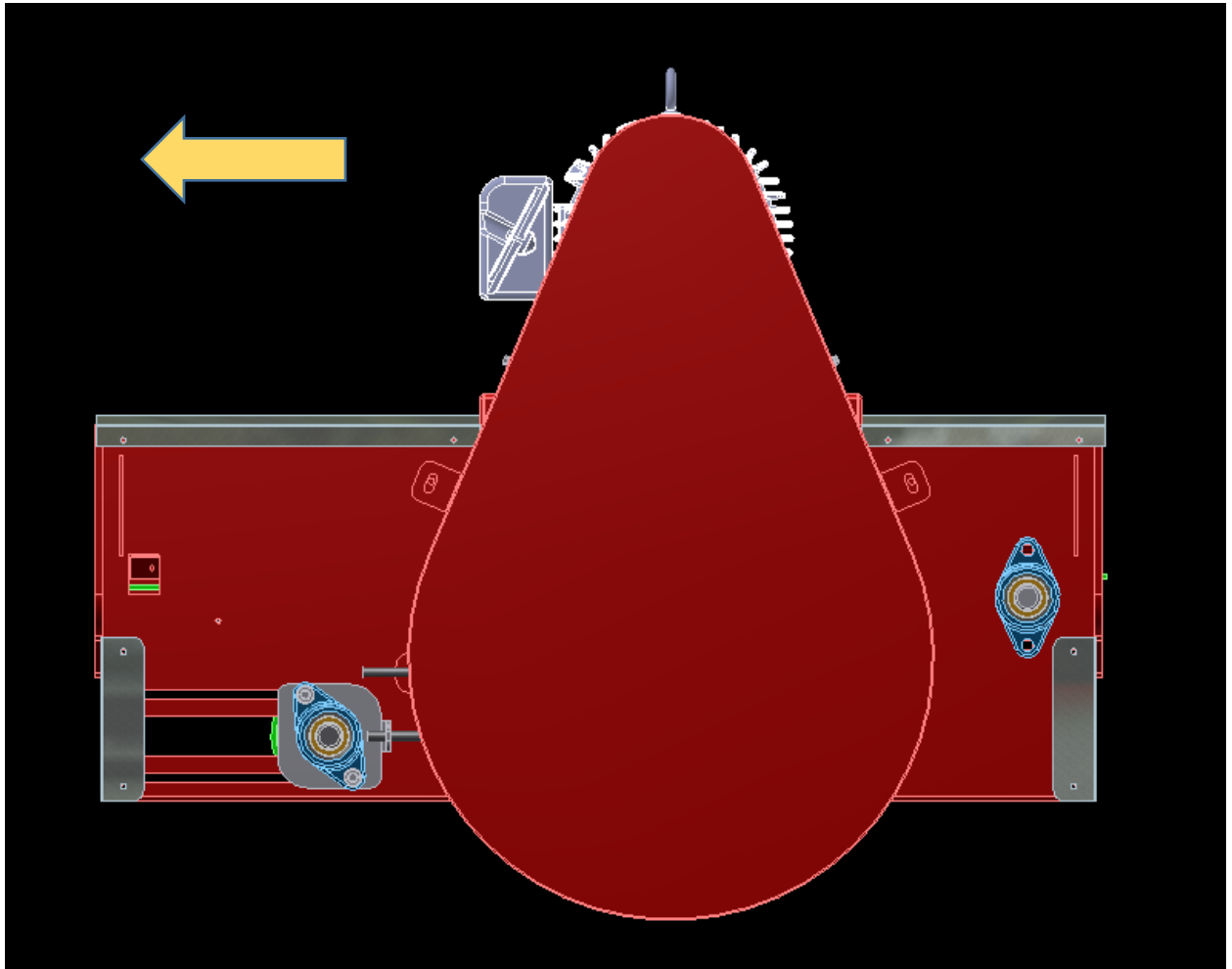

7. Attach the two discharge ends

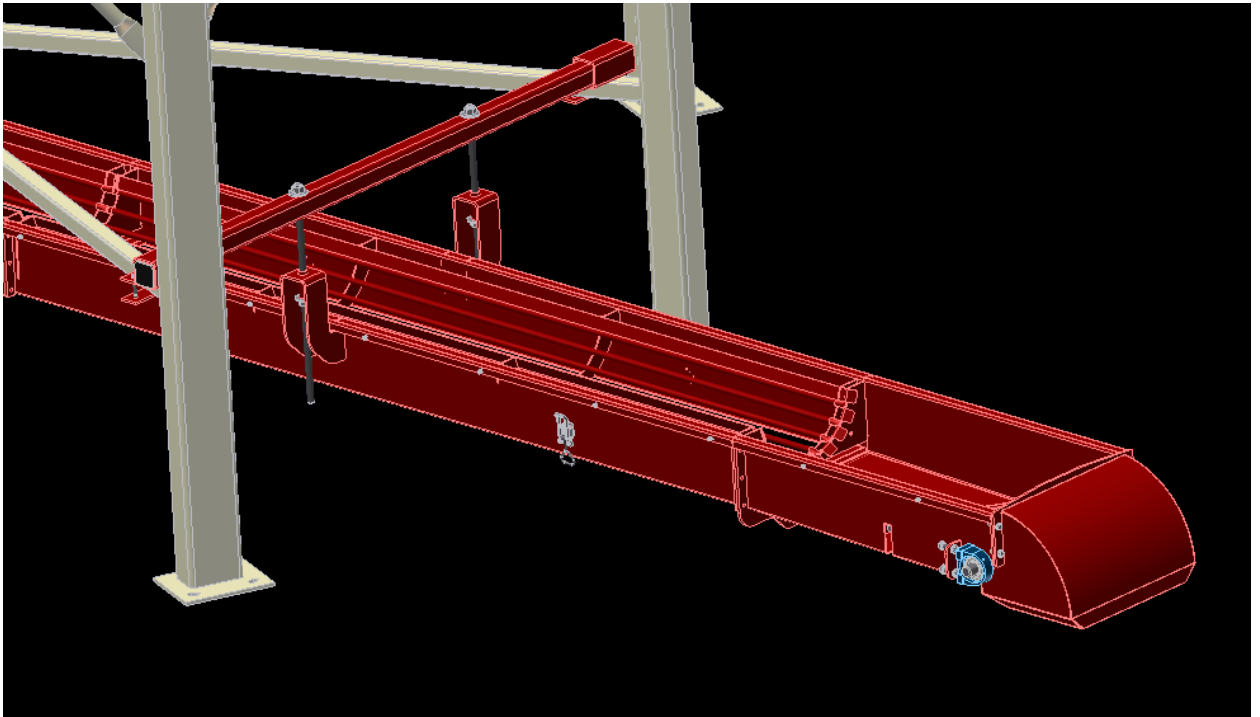

8. Install the conveyor belt. Note how the belt is fed through the s-drive and the discharge ends

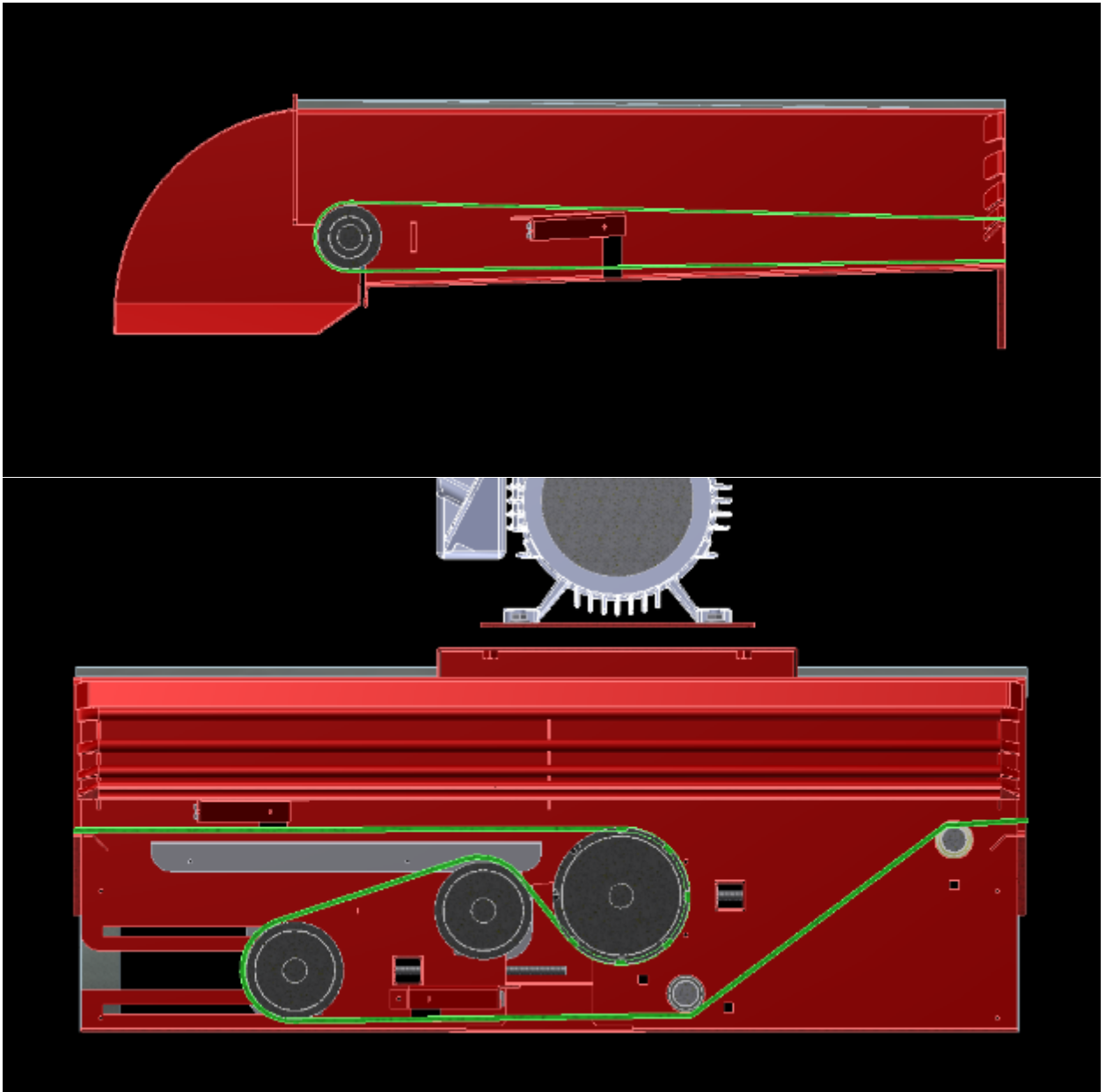

9. With the belt fed through the conveyor cut off any extra length so the belt is just as long as needed with no extra.
10. Position the “splash cover” so it’s just touching the belt and then secure it in place using self-drilling and self-tapping screws. This will prevent seed from falling off the belt when it comes out of the bin.

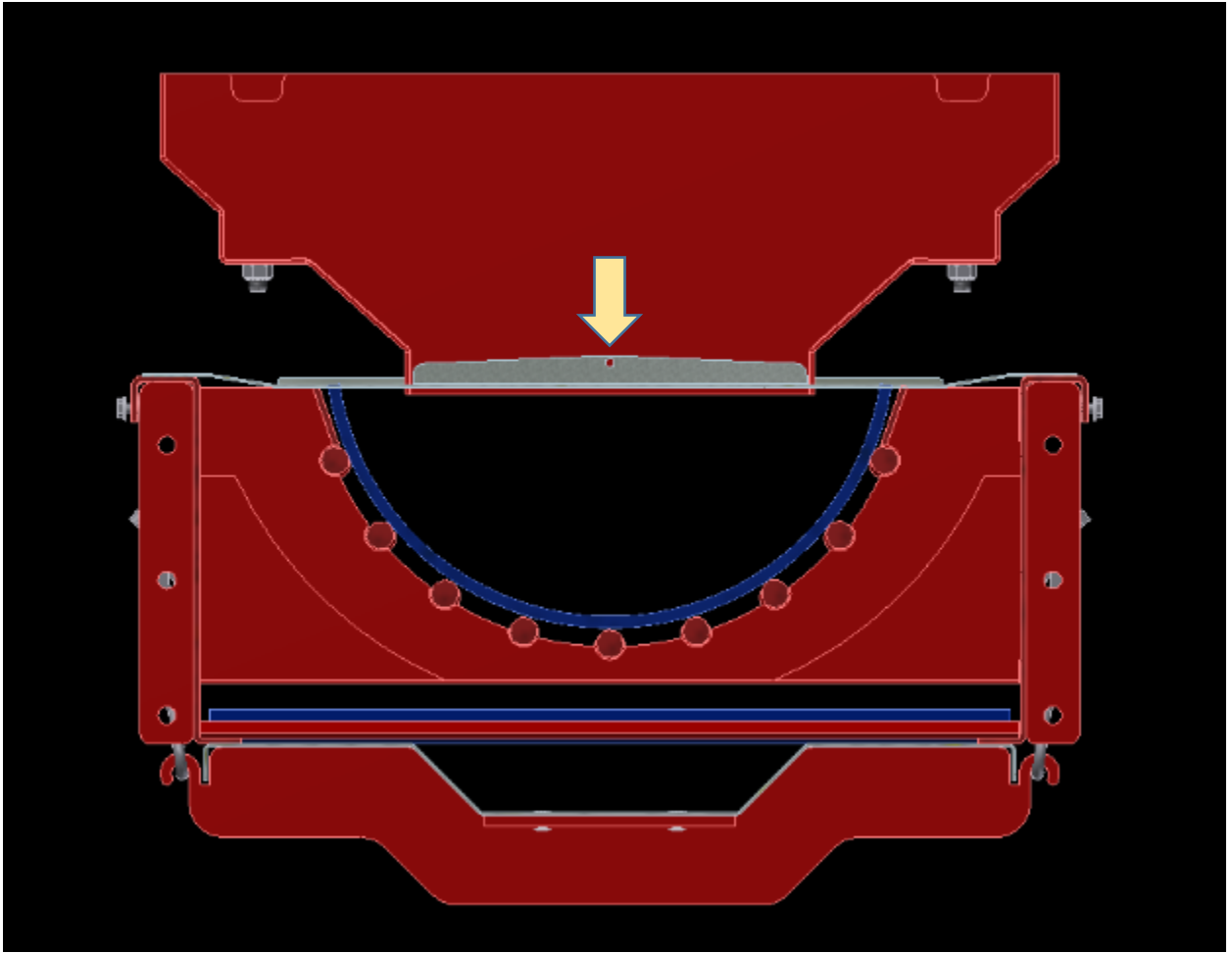

11. Cut the top galvanized covers so they will fit around the transition

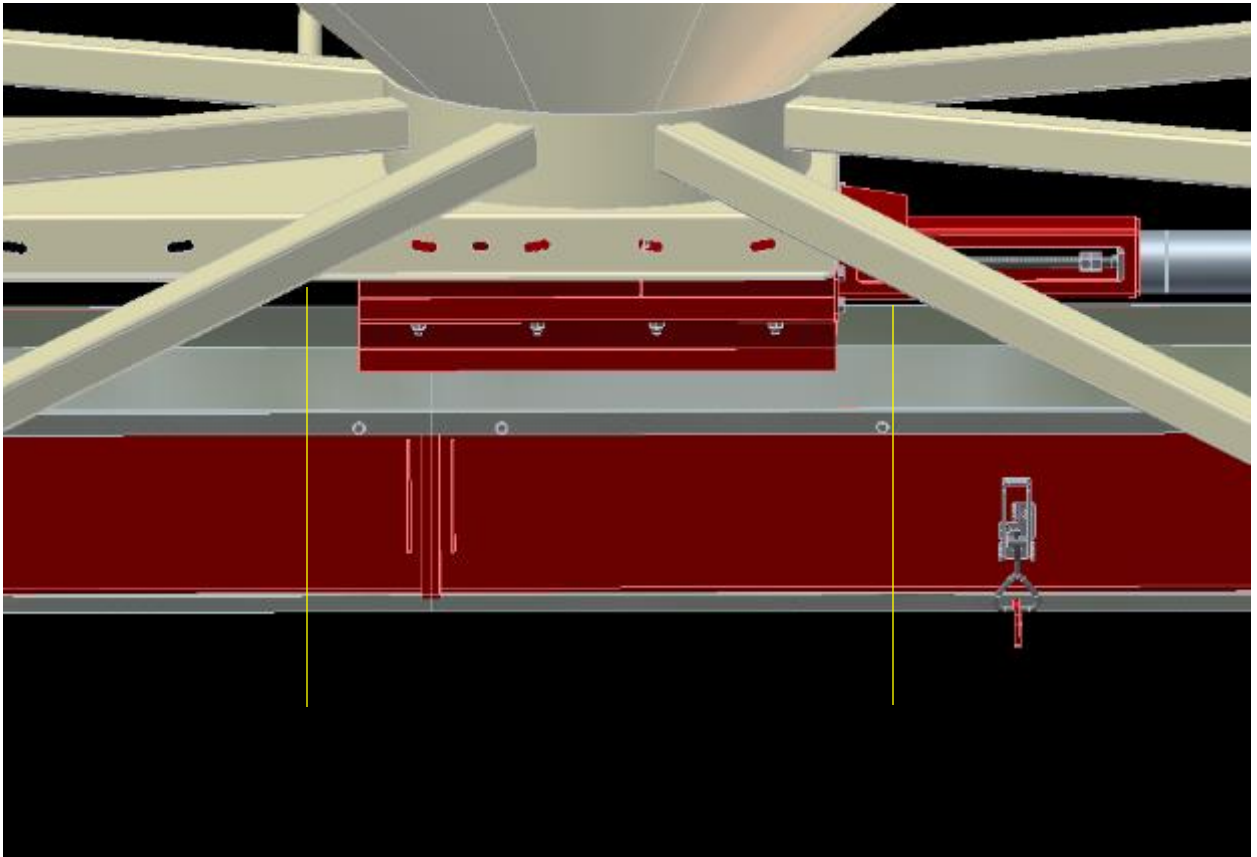

12. Position the top 2 galvanized covers (shown in green and blue) to cover up the cuts made in the step before

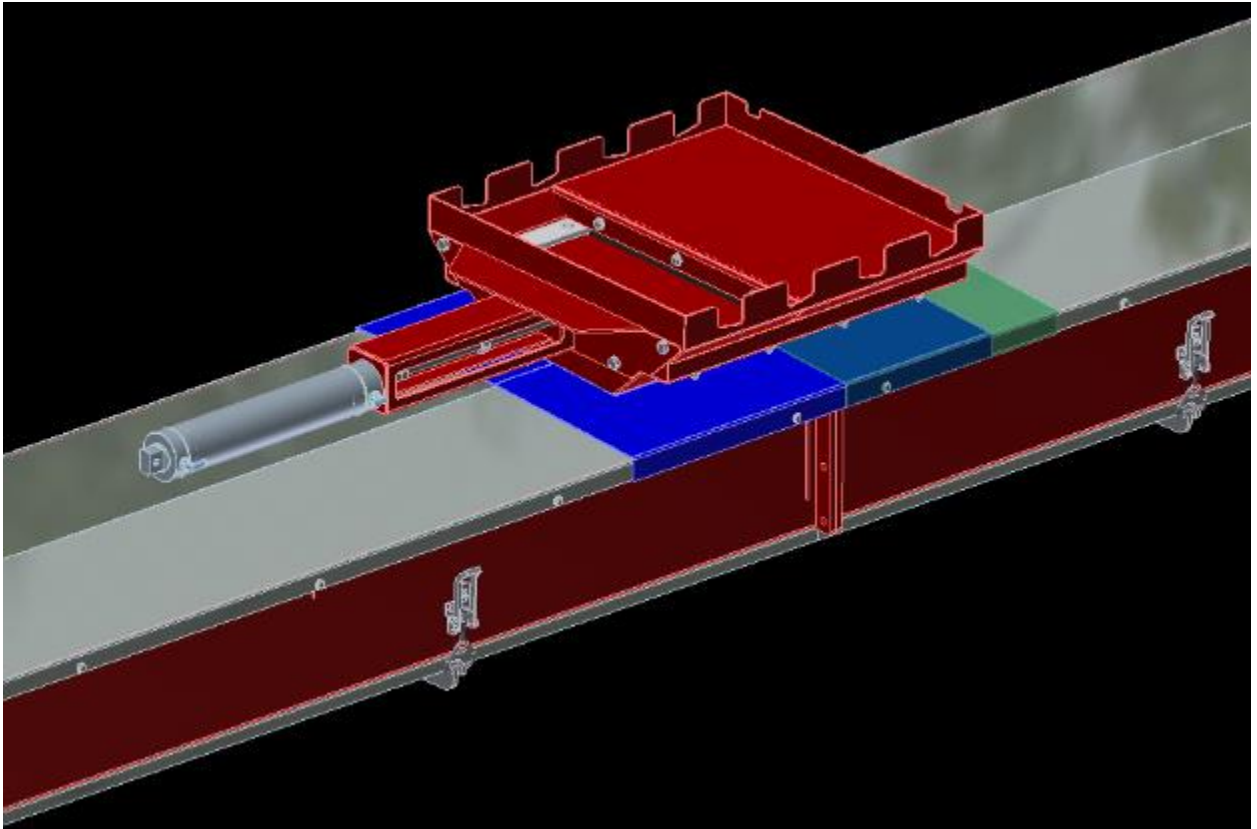

13. Tension the belt using the slack adjuster on the s-drive section.
- Tighten the belt just enough so that it turn when the conveyor is running empty. Then further tighten the belt so the slack adjuster roller moves between $\frac{1}{4}$ " and $\frac{1}{2}$ ". Test the belt running in both directions
 - The first few times you run the conveyor with product be prepared to make adjustments to the belt tension.
 - The first few cold days of the season be prepared to make adjustments to the belt tension
14. Once the belt is running ensure the belt is tracking in the middle of each of the rollers. If the belt is moving to the left of the roller then move that side of the roller out slightly in order to push the belt over to the other side. The same goes for moving a belt that is too far to the right.
15. With the belt running in the opposite direction ensure it is tracking properly and has adequate grip.
16. If the belt is squealing or speeding up or slowing down slightly this is an indication of improper belt tension or tracking.